

INSTRUCTION

For

EMCO magnetic level indicator type LI

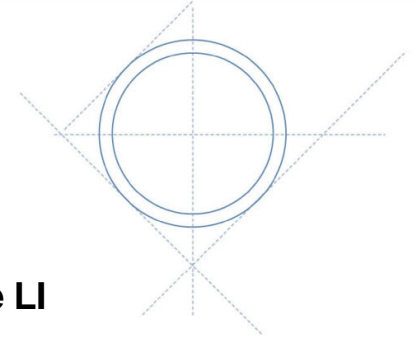

1. Application.

EMCO magnetic level indicators series LI indicates the liquid level of vessels and tanks locally without power supply.

The liquid level detection is safe, reliable and maintenance free.

2. Storage

The magnetic level indicator is an instrument and shall be handled as such.

The level indicator shall be kept clean and dry during storage.

It is important that the level indicator is kept away from permanent magnets and other magnetic items.

3. Installation

Before installing the level indicator, make sure that the flange size and pressure rating match the flanges on the vessel. The relevant process data such as pressure, temperature, density and fluid is marked on the label at the bottom of the level indicator. Check that the indicated process data match the actual process data.

Remove the blind flange at the bottom.

The float is at one end marked with design pressure and density. This end is the top end of the float.

Before inserting the float into the standpipe make sure that the float is clean and free from dirt and iron (magnetic) particles, which may disturb the free movement of the float in the standpipe.

Mount the bottom flange. As the float contains a ring magnet the direction of the indicator rail can be chosen to suit the application.

4. Putting into service

It is recommended to use shut off valves suitable for isolation for servicing the level indicator if required

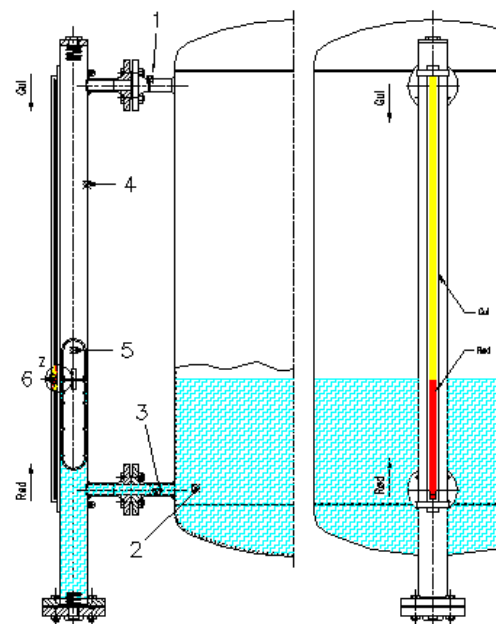

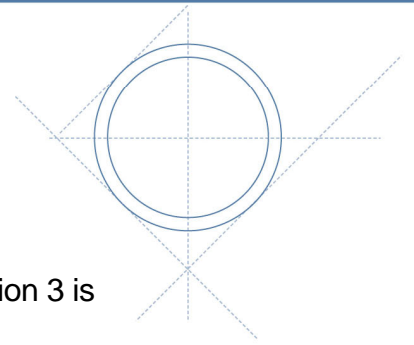

The valve at position 1 is opened slowly. Then the valve at position 3 is opened slowly.

The liquid is now entering into the standpipe raising the float to a height equal to the liquid level in the vessel.

The indication is red below liquid level and yellow above.

Is the level indicator out of service for inspection the shut off valve at position 3 is closed followed by valve at position 1.

Open the drain plug or drain valve and drain the level indicator.

The level indicator including the float may now be inspected.

5. Maintenance

Only in cases where the measured fluid contains particles which can influence the free movement of the float purging through the 2 vent and drain connections is necessary. Otherwise no maintenance is required.

6. Trouble shooting

Trouble	Possible cause	Solution
No indication of liquid level in spite of liquid in the standpipe	<ol style="list-style-type: none"> 1. The float is stuck in the standpipe 2. Leaking float. 3. Collapsed float 	<ol style="list-style-type: none"> 1. Clean standpipe and float 2. Change float, inform of process data 3. Change float, inform of process data
Failure of reed switch in spite of correct level indication	<ol style="list-style-type: none"> 1. Switch wrongly connected. 2. Switch failure due to too high electrical load 	<ol style="list-style-type: none"> 1. Compare the wiring diagram and the switch. 2. Reduce the load.